

Special offer



Welcome to the world of ALLMATIC universal clamping technology

TITAN SC 125 *limited edition*

Order no.: 2028 / 125

Scope of supply:

- High-pressure vice with step jaws
- 1 torque wrench
- 4 side clamps
- 4 gripper inserts (2301/000)
- 3 socket screw wrenches

Offer valid
while stocks last

€ 1,750
plus. VAT

Area of application:

- Can be used for horizontal and **lateral** clamping – is therefore suitable for vertical CNC-controlled milling machines.

Customer benefits:

- Introduction to the world of clamping technology without additional expense for the vice.
- Fully **compatible** with all existing vices from the LC / TC / Titan product ranges.
- 1st and 2nd clamping without the need to retool jaws.
- Clamping of unmachined parts, such as flame-cut and sawn materials (of up to approx. 1000 N/mm²), using screw-in gripper inserts (1st clamping).
- Clamping of parallel pre-machined workpieces using the step jaws (2nd clamping).
- Activation of full grip function via optional clamping jaws.

Product features:

- Its polished jaws give the TITAN the high precision required for the machining of your workpieces.
- Fully enclosed **gripping spindle** for the clamping and machining of unmachined parts.
- **High-pressure spindle with mechanical power intensifier** (operation with torque wrench). This enables machining, even in cases where clamping to the table is awkward.
- The vice has a robust GGG 60 base; the top, bottom and side surfaces are all polished.
- 4 x M8 threads for workpiece stop.
- Precise aligning slots on the polished bottom surface for optimum alignment on the machine table.
- Click quick change system for false jaws and parallels.

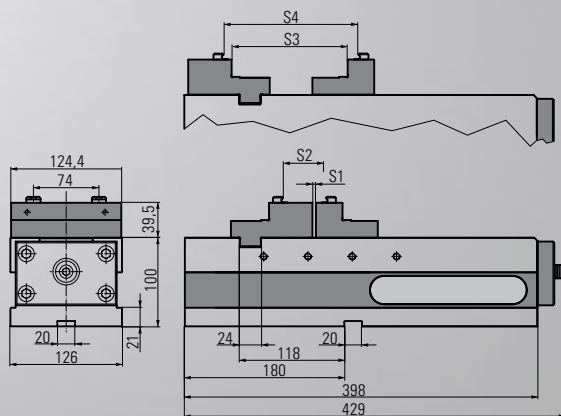

Clamping width in mm	
S1	0 - 182
S2	52 - 224
S2 round workpieces	dia. 88 - 220
S3	131 - 313
S4	160 - 332

Max. torque	Nm	30
Max. clamping force	kN	40
Weight	kg	35



The optional clamping accessories of the TITAN 125 range enable the easy and secure clamping of unmachined parts with even the most complex workpiece geometries.

We offer an optional assortment of versatile jaws that are suitable for the clamping of pre-machined workpieces.



“The new ALLMATIC catalogue is here!”

Experience, know-how and technical expertise for the benefit of our customers. Over the next 156 pages you will find a detailed overview of our products.

Free of charge at www.allmatic.de