

MONITOR FORCES SET IMPULSES



ALLMATIC
Spannsysteme **JAKOB**



What is Industrial Monitoring?

By changing to Industry 4.0, IT and machinery are merging. The possibilities of a completely networked industrial infrastructure are unimagined: industrial facilities can be controlled centrally, external and non-specialist employees can monitor production processes from outside and control machines in real time.

Automation and digitalisation have come a long way in mechanical engineering monitored 24 hours a day. The only exception is the vice - the hobbyhorse of ALLMATIC.

Your needs - Our solutions

In times of a shortage of qualified workers, the companies that succeed in automating their production will be successful in the end. For ALLMATIC, it was clear: we will continue to develop outstanding mechanical products, but we want and need to pioneer Industry 4.0 and equip mechanical vices with monitoring and prepare them for communication with the machine.

The goal of Allmatic is to connect force monitoring to the machine!

No one is closer to the milling process than the vice. Monitoring the condition of the workpiece and the machining is essential for automation.

If the vice registers a drop in clamping force, the machine must be able to react in the future, e.g. by reducing the feed or by standstill of the control system.

Even Allmatic is not spared the shortage of qualified personnel. That is why we are constantly working on making clamping devices intelligent and supporting workers.

Discover the new SENSE SERIES, all about clamping force monitoring and what the product can do for you and your production.

THE FLEXIBLE

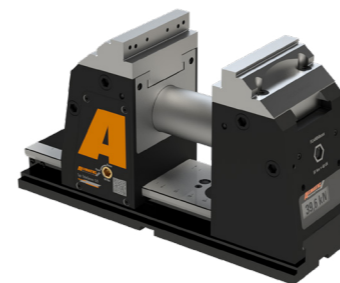

THE POWERFUL

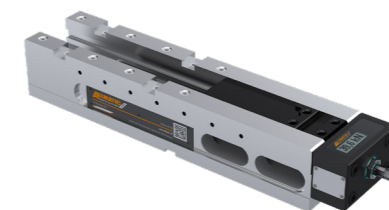

THE MUST HAVE



CLAMPING FORCE MONITORING

Digitalisation must take simple things off people's hands and support them in complex processes. Mapping the clamping force during milling is an interesting example of this.

Monitoring the clamping force at the workpiece allows you to...

- ✓ Safely clamp workpieces - by monitoring the correct clamping force
- ✓ Analyse milling processes and optimise cutting values
- ✓ Immediately recognise fluctuations or drops in clamping force

Monitor each Sense product - up to 8 devices simultaneously!



Your benefits

- ✓ **Monitoring clamping forces** during machining
- ✓ **Monitor multiple** devices **simultaneously**
- ✓ **Storing and analyzing data** from the last 24 hours
- ✓ Coming soon:
Synchronizing relevant **machine data** in **real time**

TRANSFER TO DEVICES

In addition to showing the clamping force directly on the display on the device, the data can also be displayed via Bluetooth (low energy) on a PC, HMI (web browser) and mobile phone:



SenseConnect - App

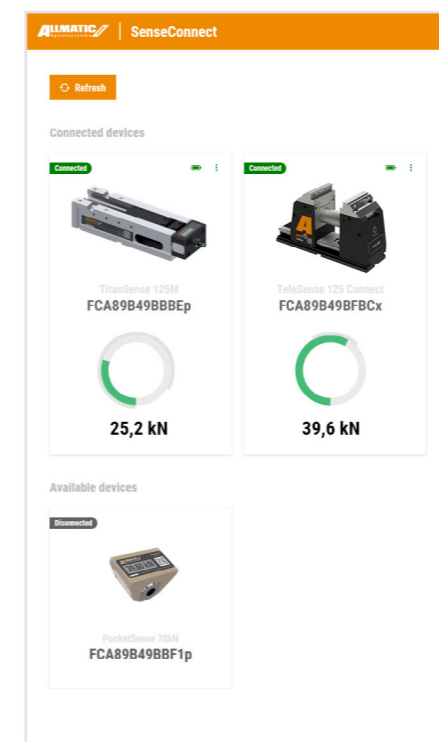

Number of transmitters	1 - 8
Receiver	Phoenix Contact module
Installation on...	Siemens EdgeBox
Display of...	<ul style="list-style-type: none"> • Clamping force (value & graph) • Battery status • Machine data (soon)
Adjusting limits	✓
Warnings (< limit >)	✓
Data export	✓
Rename devices	✓
Define filters (tags)	✓
Calibration	✓ (optional)

SENSE PRODUCT OVERVIEW

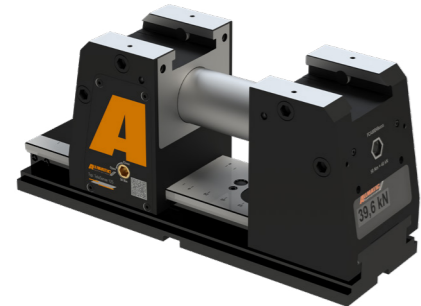

THE FLEXIBLE

TeleSense 125 Connect

- Ideal contour for 5-axis machining
- With integrated clamping force monitoring - directly on display and wireless to end device
- High clamping force of 40 kN at 50 Nm tightening torque due to spindle with force amplifier
- Jaw width 125 mm
- Clamping range 0-199 mm; with extension up to 672 mm
- Universal quick change jaw
- Compatible to the movable jaws of CentroGripp, T-Rex, NC8 and Titan 2
- Adjustable with only one tool
- Pull down possible

THE POWERFUL

TitanSense

- Integrated clamping force monitoring. Monitor clamping force while machining
- Process-reliable clamping with high repeatability
- Horizontal and vertical installation - Ideal for 3- and 4-axis machines
- Clamping of raw and pre-machined parts (parallel, round and irregular parts) also with gripp and pull-down clamping

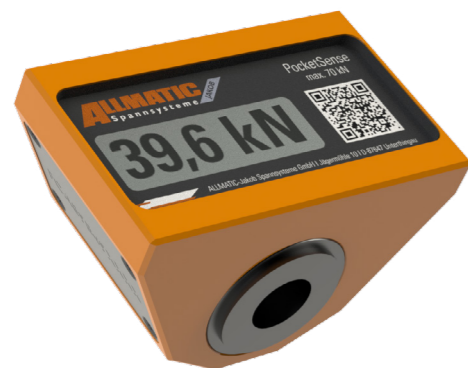
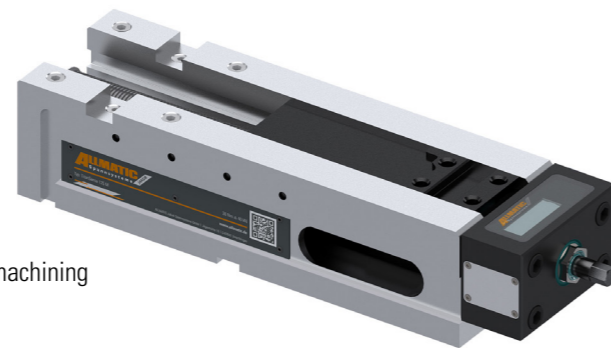

THE MUST HAVE

PocketSense

- Load cell for reliable, wireless checking of clamping forces
- Perfect for regular maintenance of vices
- Suitable for alle vices with a minimum clamping range of 61mm and pressure forces of up to 70 kN

SENSE PRODUCTS IN ACTION

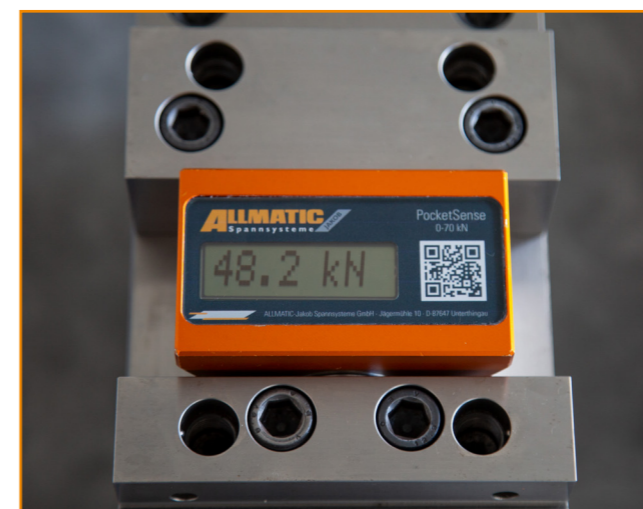
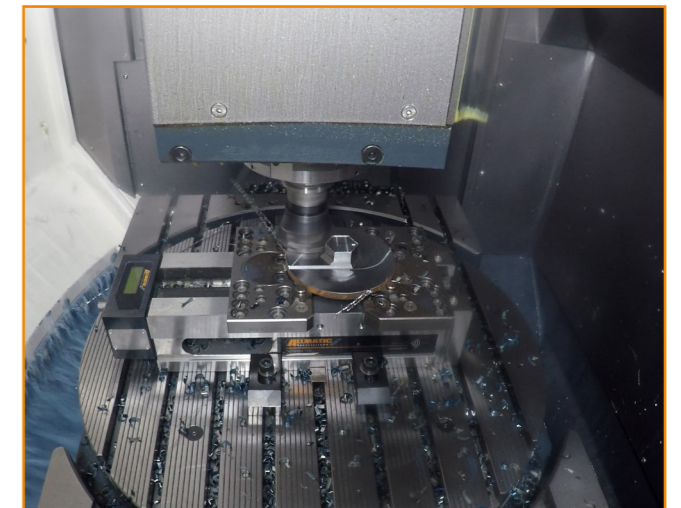
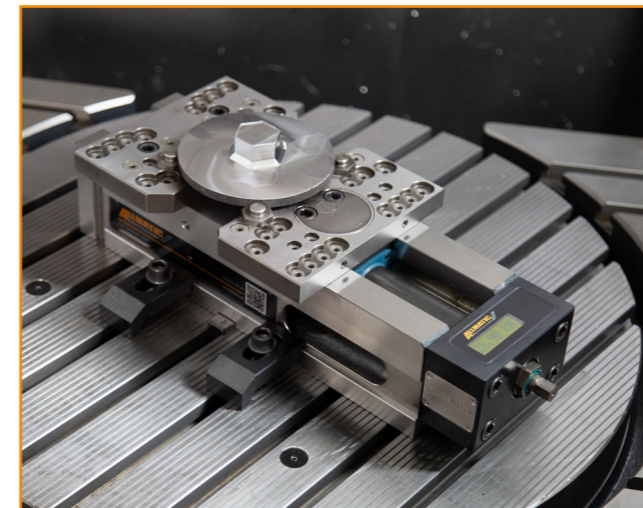

TELESENSE 125

Optimal for 5-axis machining
with integrated clamping force monitoring

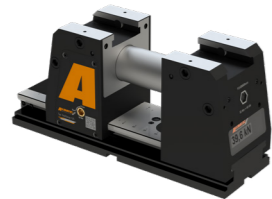

TeleSense 125 Connect

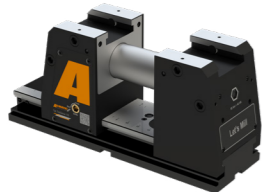

TeleSense 125

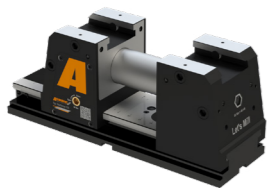

TeleSense 125 Compact

Scope of supply

- 1x TeleSense without jaws
- 1x Handcrank SW10
- 1x Torx T10
- 1x Battery AA 3,6 V (with Connect)
- Quick-Start-Guide

Technical Information

TeleSense / Size	125	125 Connect	125 Compact
Art.No.	6921868000055	6921868000066	6921868000066
Raw part machining	x	x	x
Pre-machined part	x	x	x
Integrated clamping force monitoring	*	x	
Clamping range max.	mm 199	mm 199	mm 199
Clamping range max. with spindle extension	mm 274	mm 274	mm 274
Torque	Nm 50	Nm 50	Nm 50
Clamping force max.	kN 40	kN 40	kN 40
Weight	kg 38,5	kg 39	kg 39
a	mm 398	mm 398	mm 398
b	mm 227	mm 227	mm 227
c	mm 224	mm 224	mm 224
d	mm 222	mm 222	mm 222
e	mm 204,5	mm 204,5	mm 204,5
f	mm 203	mm 203	mm 203
g	mm 192 - 217	mm 192 - 217	mm 192 - 217
h	mm 187	mm 187	mm 165
m	mm 200	mm 200	mm 200

* Can be retrofitted on request

Range of use:

- With integrated clamping force monitoring - directly on display and wireless to end device
- High clamping force of 40 kN at 50 Nm tightening torque due to spindle with force amplifier
- Jaw width 125 mm
- Clamping range 0-199 mm

Product features:

- Clamping of raw and pre-machined parts (parallel, round and irregular parts) also with gripp and pull-down clamping. Reliable clamping without pre-stamping

Maximum flexibility:

- Universal quick change jaw for a variety of different setups - thus reducing setup time and less force is required
- Compatible to the movable jaws of CentroGripp, T-Rex, NC8 and Titan 2 (adapter available)
- Extension element for enlarging clamping width

Simple handling:

- Moving of both jaw supports, fixing one jaw side
- Only one tool due to uniform wrench size 10 mm (WS10) and identical torque for force adjustment and locking
- 4 threads for workpiece stop (M8)

Simple use of the clamping force monitoring

- Long battery life
- Easy & quick battery change with standard batteries
- Display robust and splash water protected
- Monitoring unit can also be retrofitted
- Standard with locating holes \varnothing 25H6 M10 for zero-point clamping systems; inside micrometre 200 mm \pm 0,01 mm

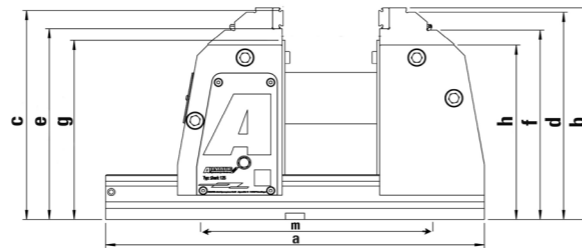

ACCESSORIES

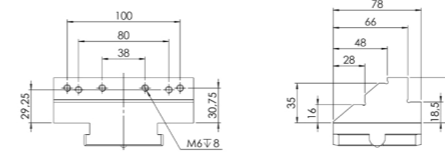

Universal quick change jaw 125

Art.No.: 6921864001031

- Clamping of raw and pre-machined parts (parallel, round and irregular parts) - including gripp and pull-down clamping
- Quick change system for rapid change of jaws
- Maximum flexibility for a variety of different setups

Product features:

- Material: hardened steel
- Functions as step jaw for clamping pre-machined workpieces
- Functions as mould jaw for round parts
- Grip strip can be screwed on
- Use of all gripp-studs of the Titan 2-series possible (except gripp-stud round h5,5)
- Gripp-strip can be attached for clamping close to the edge for materials up to 1.000 N/mm²
- Reliable clamping without pre-stamping

Jaw adapter for CentroGripp/T-Rex

Art.No.: 6921861071031

- Mobile jaws of CentroGripp/T-Rex compatible
- Quick change system for mounting the adapter on the jaw support

Jaw adapter for NC8/TITAN 2

Art.No.: 6921861070031

- Mobile jaws of NC8 125/Titan 2 125 compatible NC8 125/Titan 2 1
- Quick change system for mounting the adapter on the jaw support

Support jaw movable

Art.No.: 6921734072942

- For mounting various pull-down wedge elements, universal gripper set and gripp-studs
- Reliable clamping without pre-stamping

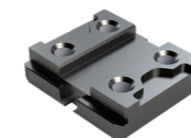
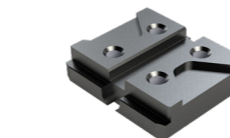

Jaws - Compatibility

When using the corresponding adapters, the mobile jaws of the following product series can be used:

- + **CentroGripp und T-Rex** with adapter 6921861071031
- + **NC8 und TITAN 2** with adapter 6921861070031

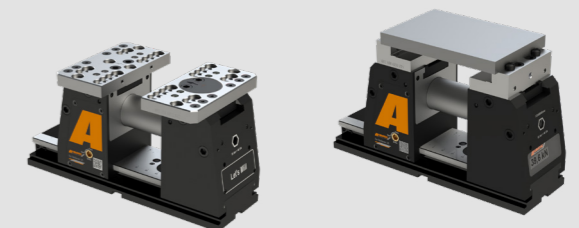

JAW OVERVIEW

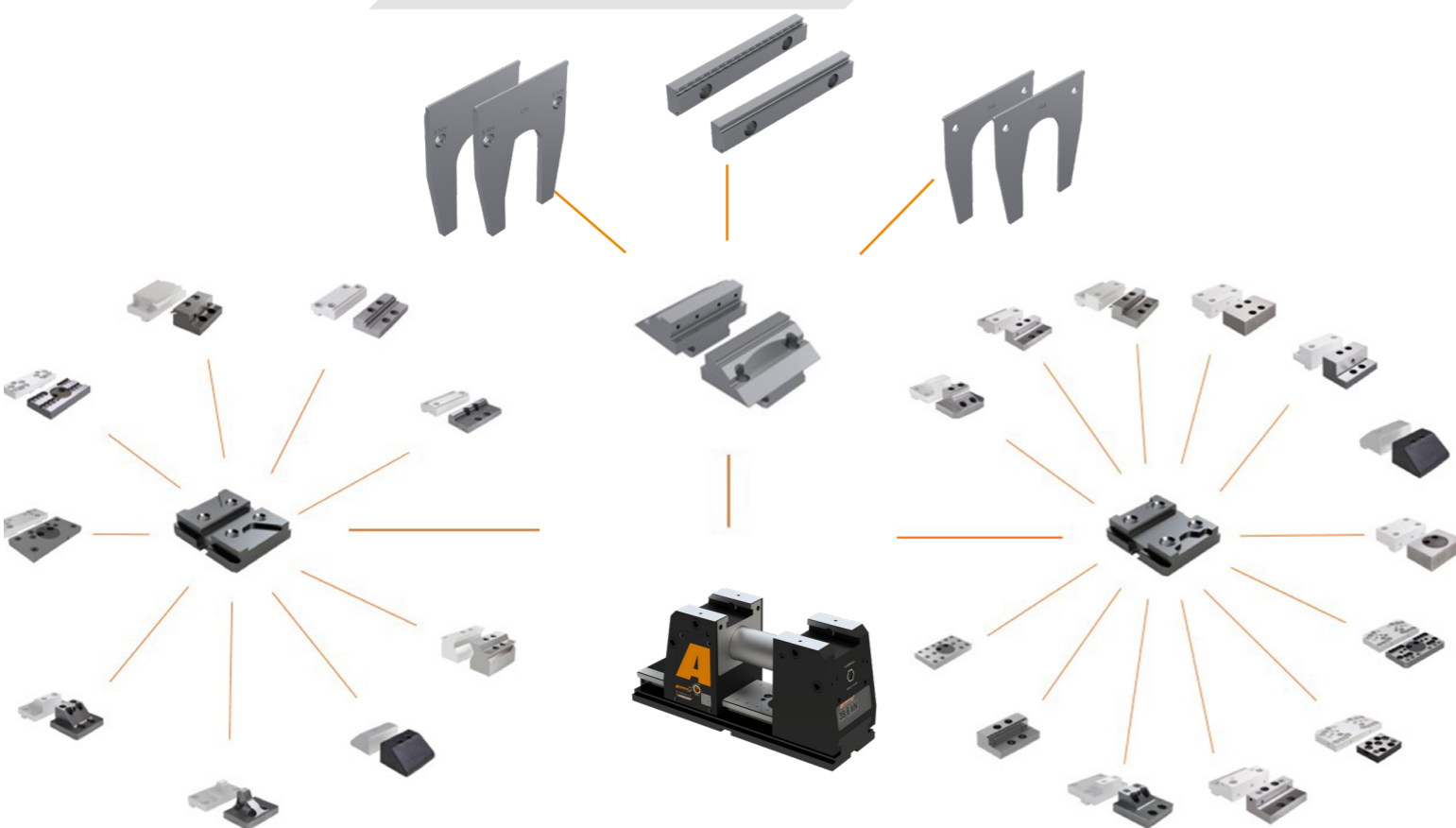

Clamping ranges

Art.No.	Description	S1		S2		S3		S4		S1 / D1		S2 / D2		S3		S4	
		0 - 127	52 - 199	S1	S2	S3	S4	S1 / D1	S2 / D2	S3	S4	S1 / D1	S2 / D2	S3	S4	S1 / D1	S2 / D2
6921864001031	Universal quick change jaw 125	0 - 127	52 - 199														
6921484002731	Step jaw movable			9,5 - 114,5	89,5 - 194,5												
6921684102031	Pull-down jaw movable			0 - 86	74,5 - 179,5	2,5 - 103,5											
6921284011231	Master jaw adapter movable			0 - 104,5	63,5 - 168,5												
6921484087031	Soft jaw movable			0 - 76,5													
6921674004731	Hard basic jaw movable			2 - 108,5	2 - 108,5												
6921884050031	Step jaw movable for gripp-studs			9,5 - 114,5 ∅ 88 - 145*	89,5 - 194,5 ∅ 88 - 221*	22,5 - 137*	114,5 - 219*										
6921834036231	Jaw 64 mm, movable with integrated gripper row			8 - 105,5	92,5 - 197,5	0 - 97,5	84,5 - 198,5										
6921834040040	Reduced-width jaw 64 mm movable for gripper studs			0 - 70,5		17,5 - 88*	161 - 268*										
6921834045031	Gripper jaw movable with integrated gripper row			8 - 107,5	94,5 - 199,5	0 - 99,5	86,5 - 191,5										
6921734072842	Support jaw movable, pivot			∅ 70 - 270*		70 - 238*											
6921884004842	Support jaw movable, rigid			∅ 70 - 215*		32 - 213*											
6921734072942	Support jaw movable			∅ 70 - 270*		70 - 238*											
6921884002041	Step jaw movable, carbide - coated							19,5 - 124,5	113,5 - 218,5	11,5 - 116,5	105,5 - 210,5						
6921884041041	Reduced-width jaw, 20 mm movable							29,5 - 134,5		21,5 - 126,5							
6921534001031	Prismatic jaw, horizontal movable							∅ 17 - 42	∅ 38 - 104								
6921884102031	Universal pull-down jaw movable							0 - 101,2	65,5 - 170,5	13,5 - 118,5							
6921534087031	Soft jaw movable							0 - 88,5									
6921884040040	Reduced-width jaw, 64 mm movable							0 - 89,5									
6921534036931	Gripper jaw movable with integrated gripper row							18,5 - 123,5	86,5 - 191,5	12,5 - 117,5	80,5 - 185,5						
6921534036031	Jaw 64 mm, movable with integrated gripper row							18,5 - 123,5	86,5 - 191,5	12,5 - 117,8	80,5 - 185,5						
6921884072242	Support jaw for universal gripper set movable, pivot									0 - 157**							
6921884072042	Support jaw for gripper studs movable, pivot									27 - 208*							

* When using grip insert 2-point h6.7 / Ranges vary based on flu operations
 ** When using universal grip set

ACCESSORIES

Pull-down parallels h170 / h148 (Pair)

Art.No.: 6921865005131 / 6921865015131

- For levelling the workpiece on the universal quick change jaw
- Can be screwed to the jaw support
- Pull-down parallels h148 (TeleSense 125 Compact)



Parallels h144 / h122 (Pair)

Art.No.: 692186500503

- For supporting the workpiece
- Can be screwed to the jaw support
- For parallel raising of workpieces
- Parallels h122 (TeleSense 125 Compact)



Gripp strip 125 reversible Smooth strip 125 carbide coated

Art.No.: 6921864010031 Art.No.: 6921864010131

- Grip strip reversible and smooth strip for mounting on the Universal quick-change jaw 125
- For clamping unmachined parts close to the edge, step 4 mm
- Gripper-strip with fine & rough teeth
- Gripper studs suitable for materials with a strength of up to approx. 1000 N/mm²



Hand Crank WS10

Art.No.: 6921865508131

- Uniform key width 10 mm for pre-adjustment and locking
- Please use a torque wrench for clamping



Side clamps (pair)

Art.No.: 6921865000031

- For securing the vice on the machine table
- We recommend the use of 6 side clamps per vice

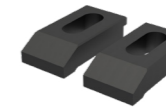

Hexagonal socket 10-3/8 inch

Art.No.: 0651130411610

Hexagonal socket 10-1/2 inch

Art.No.: 0651130411710



Combination options for a larger range

Increasing the range of the TeleSense 125 up to a maximum range of 672 mm.

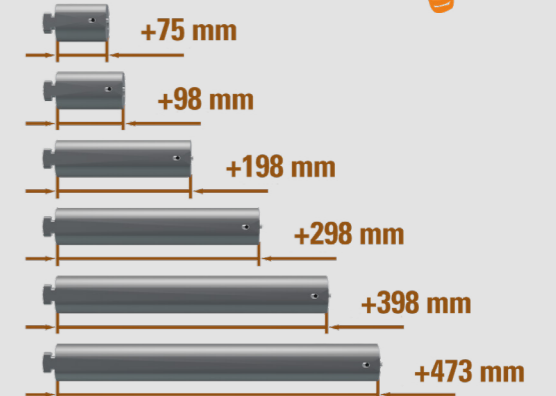
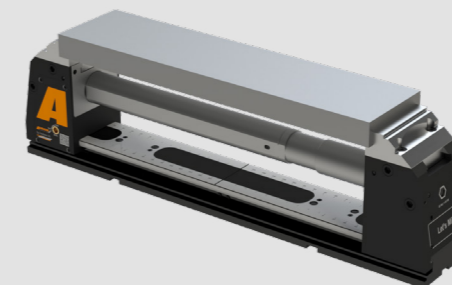

TITANSENSE

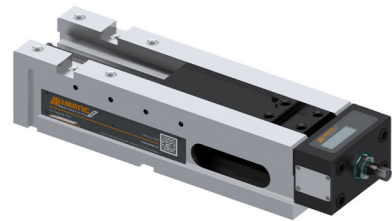

TitanSense 125 M



TitanSense 125 L

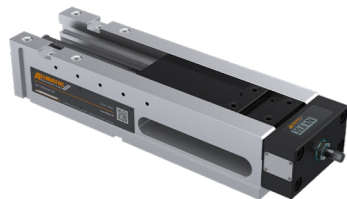

TitanSense 160

Range of use:

- Integrated clamping force monitoring. Monitor clamping force while machining
- Process-reliable clamping with high repeatability
- Horizontal and vertical installation - Ideal for 3- and 4-axis
- Clamping of raw and pre-machined parts (parallel, round and irregular parts) also with gripp and pull-down clamping

Product features:

Maximum safety:

- Monitoring of the clamping force during clamping and machining due to integrated, electronic measuring system. Readout directly on display and via wireless transmission to terminal device (via Bluetooth BLE)
- Encapsulated spindle with force amplifier (IP65). Input of max. 30 Nm for 40 kN clamping force
- Operation via torque wrench

Flexible use:

- All jaws of the Titan2/NC8 series can be used
- Jaws reversible
- Unmachined parts in highly varied materials or with complex geometries, can be clamped securely. Different gripp-studs for materials up to approx. 1400 N/mm² strength
- Quick change for attachment jaws and parallels
- Titan2 spindle can also be used without monitoring
- Holes for workpiece stop, angular drive and extension
- Sides are ground
- Bottom side with alignment grooves and locating holes Ø 25H6 M10 for zero-point clamping systems, inside micometre 200 mm ± 0,01 mm

Simple use of the clamping force monitoring:

- Clamping force can be recorded with all compatible jaws, as the measuring unit is in the spindle
- Transmission range up to 20 m
- Long battery life
- Easy & quick battery change with standard batteries
- Display robust and splash-proof
- Operating temperature between 10° C and 40° C
- Individual QR code for fast access to technical information, accessories, spare parts and service

TECHNICAL INFORMATION

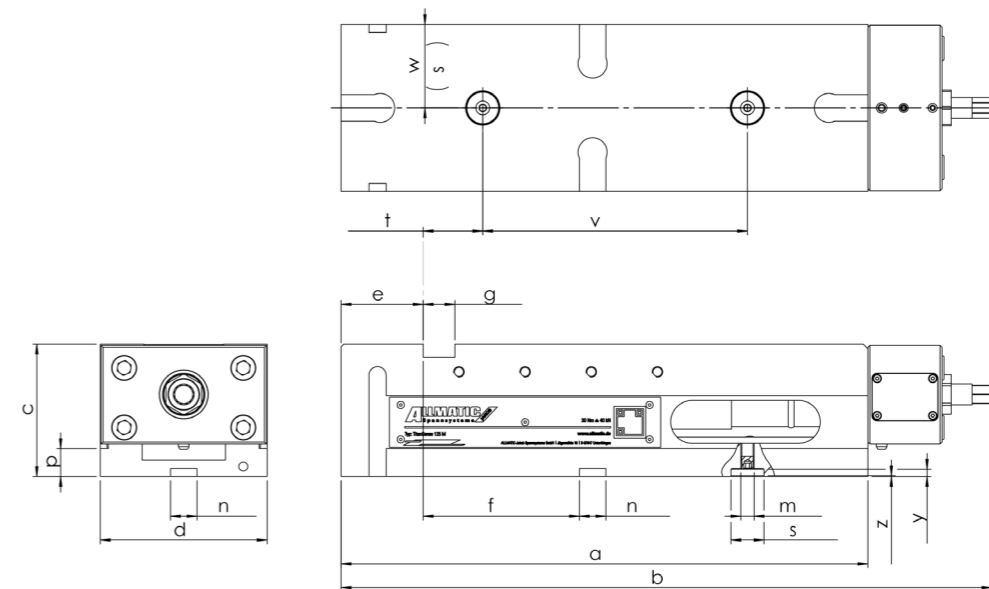

TitanSense / Size	125 M	125 L	160
Art.No.	6921838000866	6921838000166	6921848000166
Raw part machining	x	x	x
Pre-machined part	x	x	x
Clamping range maximal	mm 504	636	493
Torque	Nm 30	30	30
Clamping force max.	kN 40	40	40
Mounting holes	mm x		
Weight	kg 35	40	52
a	mm 398	530	530
b	mm 492	624	624
c	mm 100	100	115
d	mm 126	126	164
e	mm 21	21	21
f	mm 118	216	164
g	mm 24 H8	24 H8	30 H8
m	mm M10		
n	mm 20 H7	20 H7	20 H7
s	mm Ø 25		
t	mm 45		
v	mm 200		
w	mm 63		
y	mm 5,5		
z	mm 0,5x45°		

Suitable accessories

	125 M	125 L	160
Side clamps	Art.Nr. 6921025000031		
DUO Side clamps	Art.Nr. 6921285000031		
Torque wrench	Art.Nr. 0651114113188		
Clamping range enlargement	Art.Nr. 6921685008055		6921705008055
Console	Art.Nr. 6921885010042		
Workpiece stop	Art.Nr. 6921285650144		
Workpiece stop	Art.Nr. 6921685670042		

POCKETSENSE

Range of use:

- Load cell for reliable, wireless checking of clamping forces
- Perfect for regular maintenance of vices
- Suitable for alle vices with a minimum clamping range of 61 mm and pressure forces of up to 70 kN

Product features:

- Clamping force indication directly on display and other devices
- Energy-efficient due to standby mode and battery life up to six months in two-shift operation
- Compact contour
- Aluminium alloy casing
- Important: The whole surface of the measuring disc must be clamped in the vice

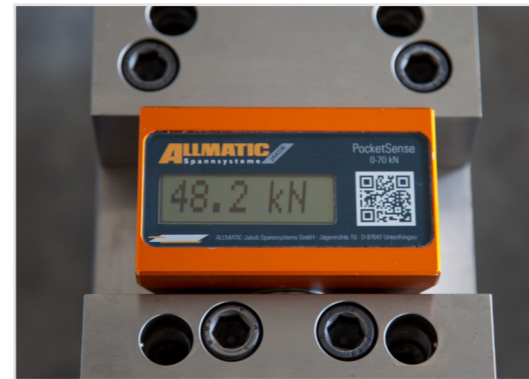
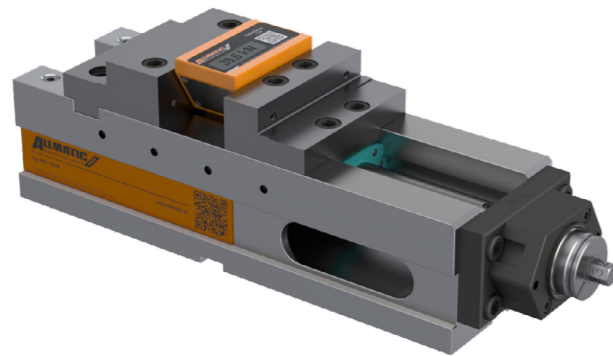
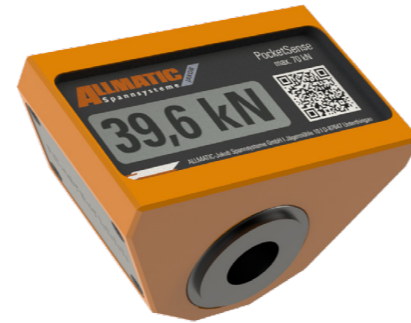

Integration of measurement technology into other products

The technology behind a monitored vice and load cell can also be adapted to many other areas. For example, it can also be installed directly in clamping jaws or even used as shims. Compressive forces of the most varied types can be checked with a very high degree of accuracy via the measuring discs. The discs - comparably small as a 1€ coin - are available in three different versions: M12 (5t), M16 (10t) and M20 (20t). Measurements are possible at an operating temperature of -20 to +70 °C, and the body is also very robust and waterproof.

FEEDBACK COSTUMER

Test customer: Mayer Feintechnik GmbH
Test product: TeleSense 125 Connect
Machine: DMU 60dVo Bj. 2022
Work piece: Rectangular and round semi-finished products

High-quality, sophisticated 5-axis vice

„We had the vice in our house for about 4 weeks. All employees who were involved in the test are convinced by the product in terms of quality, flexibility and precision. I would recommend the 5-axis vice without reservation. It is a very high quality product, with which our clamping tasks for 5-axis machining can be realised in a very short time. The accessories are extensively designed and the mounting options are absolutely future-proof“

Frank Neuschulz, Managing Director of Mayer Feintechnik GmbH

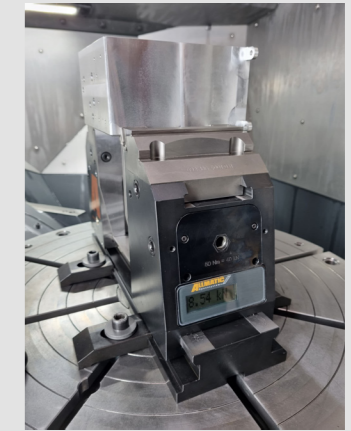

Test customer: Zeiler GmbH
Test product: TeleSense 125 Connect
Machine: DMU 70
Work piece: Steel, aluminium, plastic and cast parts

Maximum flexibility and process reliability

„We had the new TeleSense 125 Connect 5-axis vice in use on our DMU 70 for several weeks. We clamped different workpieces made of steel, aluminium, plastic or cast iron on it and also tested the pull-down function. In terms of handling, accessibility and vibration behaviour, we were always very satisfied. We see a great advantage for our production in the clamping force monitoring. Thanks to the display, we always have the clamping force in view and can react quickly to fluctuations. In addition, we can dose the force very finely, which is especially important when machining different materials. The TeleSense vice has convinced us throughout that we now use it permanently in our production.“

Benno Zeiler, Managing Director Zeiler GmbH



Delivery of the first TeleSense Connect to Zeiler GmbH
 The first 5-axis vice with integrated clamping force monitoring!

APPLICATIONS

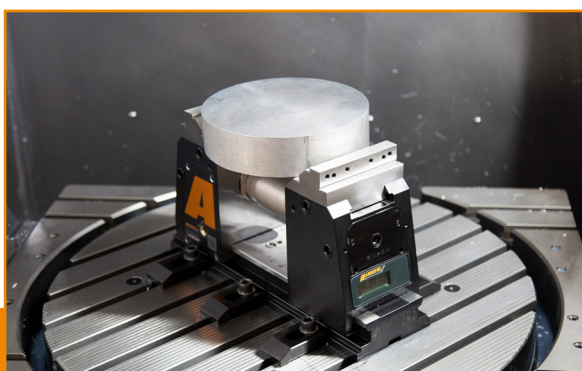
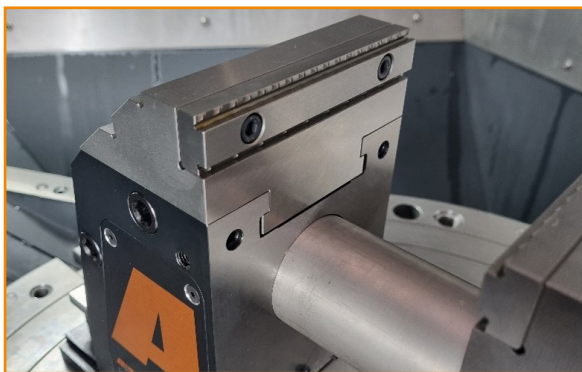
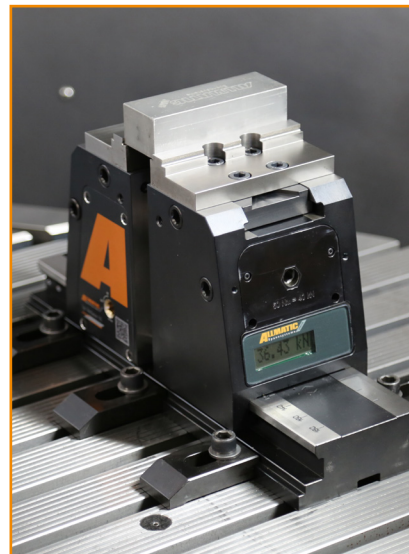
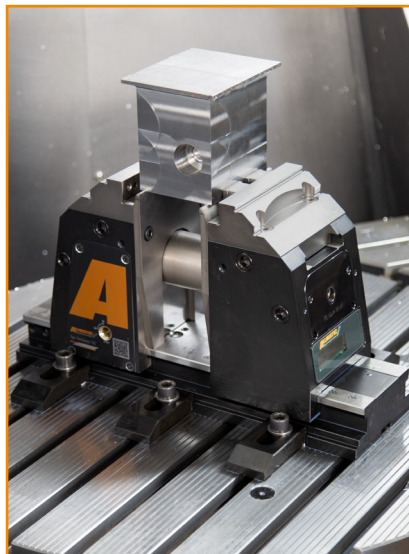
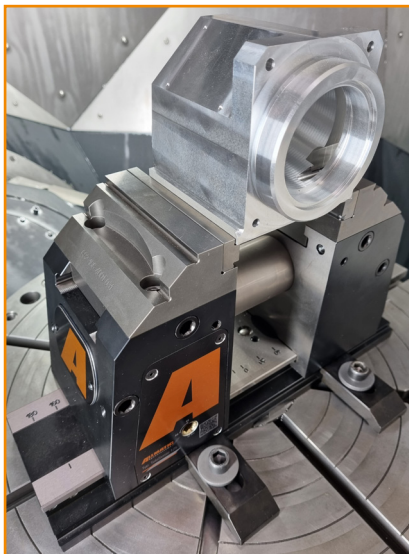

ALLMATIC-Jakob Spannsysteme GmbH

Jägermühle 10

+49 8377 929-0

87647 Unterthingau

sales@allmatic.de

www.allmatic.de